

Operating and installation instructions

Multi-temperature wine cabinet with freezer compartment

EN

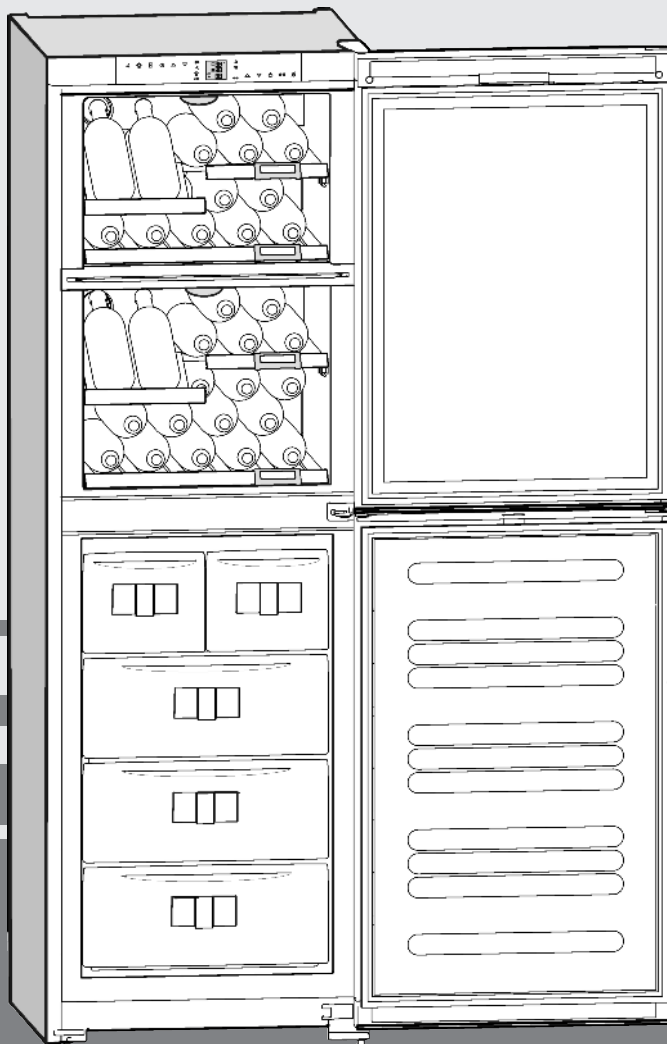

290816 **7084680 - 01**

SWTNes/WTNes ... 6

LIEBHERR

Appliance at a glance

Contents

1 Appliance at a glance	2
1.1 Description of appliance and equipment.....	2
1.2 Appliance range of use.....	2
1.3 Conformity.....	3
1.4 External dimensions of the appliance.....	3
1.5 Saving energy.....	3
1.6 HomeDialog.....	3
2 General safety information	3
3 Controls and displays	4
3.1 Operating and control elements.....	4
3.2 Temperature display.....	5
4 Putting into operation	5
4.1 Transporting the appliance.....	5
4.2 Installing the appliance.....	5
4.3 Changing over the door hinges.....	6
4.4 Water connection.....	10
4.5 Insertion into a row of kitchen units.....	10
4.6 Disposing of packaging.....	11
4.7 Connecting the appliance.....	11
4.8 Switching on the appliance.....	11
5 Control	11
5.1 Brightness of the temperature display.....	11
5.2 Child proofing.....	11
5.3 Door alarm.....	12
5.4 Temperature alarm.....	12
5.5 Freezer compartment.....	12
5.6 Wine zone.....	14
6 Maintenance	15
6.1 Replacing the activated charcoal filter.....	15
6.2 Defrosting with NoFrost.....	15
6.3 Cleaning the appliance.....	15
6.4 Cleaning the IceMaker.....	16
6.5 Customer service.....	16
7 Malfunctions	16
8 Decommissioning	18
8.1 Switching off the appliance.....	18
8.2 Taking the appliance out of service.....	18
9 Disposing of the appliance	18

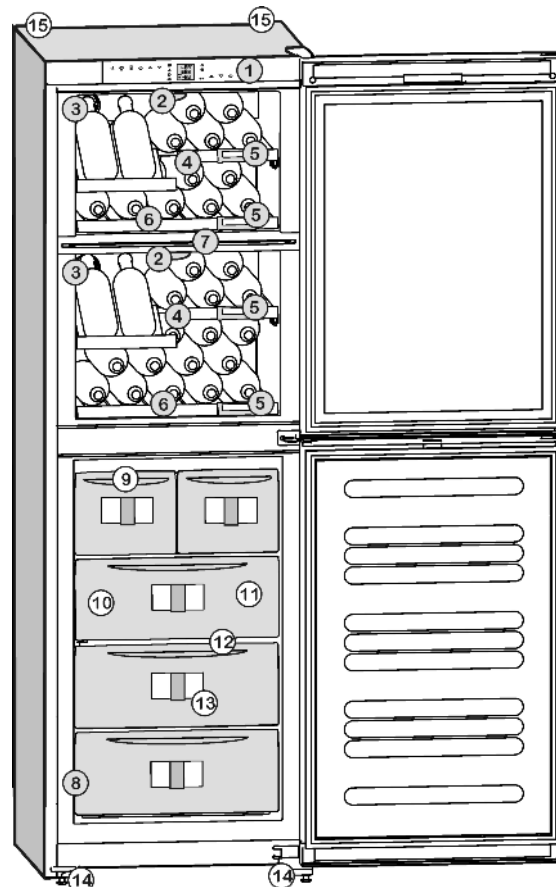

Fig. 1

- | | |
|--|--------------------------------|
| (1) Control panel | (9) IceMaker |
| (2) LED lighting | (10) Freezer compartment |
| (3) Activated charcoal filter, replaceable | (11) Cold storage accumulators |
| (4) Wooden shelf, folding | (12) VarioSpace |
| (5) Label | (13) Information system |
| (6) Wooden shelf, fixed | (14) Adjustable feet |
| (7) Separating plate with sealing lip | (15) Transport grips |
| (8) Type plate | |

1.2 Appliance range of use

Intended use

The appliance is only suitable for refrigerating wine or food in a domestic or domestic-like environment. This includes, for example, using

- in staff kitchens, bed and breakfast establishments,
- by guests in country houses, hotels, motels and other accommodation,
- for catering and similar services in the wholesale trade.

All other types of use are not permitted.

Foreseeable misuse

The following applications are expressly forbidden:

- Storing and refrigerating medicines, blood plasma, laboratory preparations or similar substances and products based on the Medical Device Directive 2007/47/EC
- Use in areas at risk of explosions

The manufacturer works constantly on the further development of all the types and models. Therefore please understand that we have to reserve the right to make design, equipment and technical modifications.

To get to know all the benefits of your new appliance, please read the information contained in these instructions carefully.

The instructions apply to several models. Differences may occur. Text relating only to specific appliances is marked with an asterisk (*).

Instructions for action are marked with a ►, the results of action are marked with a ▷.

1 Appliance at a glance

1.1 Description of appliance and equipment

Note

- Shelves, drawers and baskets are arranged for optimum energy efficiency on delivery.

Misusing the appliance may lead to damage to the goods stored or they may spoil.

Climate classifications

Depending on the climate classification the appliance is designed to operate in restricted ambient temperatures. The climate classification applying to your appliance is printed on the rating plate.

Note

► Keep to the specified ambient temperatures in order to guarantee that the appliance works properly.

Climate classification	for ambient temperatures of
SN	10 °C to 32 °C
N	16 °C to 32 °C
ST	16 °C to 38 °C
T	16 °C to 43 °C

1.3 Conformity

The refrigerant circuit has been tested for leaks. This appliance complies with the applicable safety stipulations and with directives 2014/35/EU, 2014/30/EU, 2009/125/EG, 2011/65/EU and 2010/30/EU.

1.4 External dimensions of the appliance

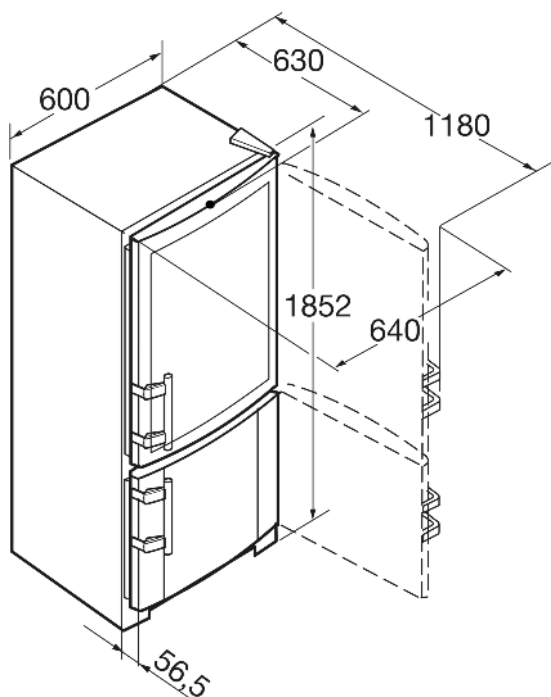

Fig. 2

1.5 Saving energy

- Pay attention to good ventilation. Do not cover ventilation holes or grids.
- Always keep the fan air slits clear.
- Do not install the appliance in direct sunlight, next to an oven, radiator or similar.

- Energy consumption is dependent on the installation conditions, e.g. ambient temperature (see 1.2) . If the ambient temperature deviates from the standard temperature of 25°C, the energy consumption may differ.
- Open the appliance for as short a time as possible.
- The lower the temperature is set the higher the energy consumption.

Dust deposits increase energy consumption:

- For refrigerators with heat exchangers dust the metal grid on the back of the appliance once a year.

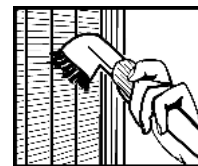

EN

1.6 HomeDialog

Depending on model and options, the HomeDialog system can be used to network a number of Liebherr appliances (situated, for example, in the basement) with a main appliance (sited, for example, in the kitchen) and control them via the latter. You will find more information on the benefits, requirements and principle of operation on the internet at www.liebherr.com.



2 General safety information

Danger for the user:

- This appliance can be used by children from the age of 8 onwards. It can also be used by people with impaired physical, sensory or mental abilities or with a lack of experience and knowledge provided that they are supervised or have received instruction in the safe use of this appliance, and about the attendant hazards. Children must not play with this appliance. Cleaning and user maintenance work must not be carried out by children without adult supervision. Children aged between 3 and 8 are allowed to load and unload the appliance. Children below the age of 3 must be kept away from the appliance unless they are under continuous adult supervision.
- When disconnecting the appliance from the supply, always take hold of the plug. Do not pull the cable.
- In the event of a fault pull out the mains plug or deactivate the fuse.
- Do not damage the mains power cable. Do not operate the appliance with a defective mains power cable.
- Have any repairs to or intervention in the appliance, and any change of the mains power cable, carried out by the customer service only or by other specialised personnel trained for the purpose.
- Only assemble, connect and dispose of the appliance according to the instructions.
- Please keep these instructions in a safe place and pass them on to any subsequent owners.

Controls and displays

- All repairs to and intervention in the IceMaker may be carried out only by service personnel or by other skilled personnel trained for the purpose.
- The manufacturer is not liable for damage caused by a faulty fixed water connection.
- Special-purpose lamps (incandescent lamps, LEDs, fluorescent tubes) in the appliance serve to illuminate the appliance interior and are not suited for room illumination.

Fire hazard:

- The refrigerant R 600a is environmentally friendly but flammable. Escaping refrigerant may ignite.
 - Do not damage the refrigerant circuit pipes.
 - Do not allow naked flames or ignition sources to enter the appliance.
 - Do not use any electrical appliances in the interior (e.g. steam cleaners, heaters, ice cream maker etc.).
 - If refrigerant escapes: remove any naked flames or sources of ignition from the leakage area. Ventilate the room well. Notify the after-sales service.
- Do not store explosives or sprays using combustible propellants such as butane, propane, pentane, etc. in the appliance. To identify these spray cans, look for the list of contents printed on the can, or a flame symbol. Gases possibly escaping may ignite due to electrical components.
- Keep burning candles, lamps and other items with naked flames away from the appliance so that they do not set the appliance on fire.
- Please be sure to store alcoholic drinks or other packaging containing alcohol in tightly closed containers. Any alcohol that leaks out may be ignited by electrical components.

Danger of tipping and falling:

- Do not misuse the plinth, drawers, doors etc. as a step or for support. This applies particularly to children.

Danger of food poisoning:

- Do not consume food which has been stored too long.

Danger of frostbite, numbness and pain:

- Avoid lasting skin contact with cold surfaces or refrigerated/frozen food or take protective steps, e.g. wear gloves. Do not consume ice cream, water ice or ice cubes immediately and do not consume them too cold.

Danger of injury and damage:

- Hot steam can lead to injury. Do not use electrical heating or steam cleaning equipment, open flames or defrosting sprays to defrost.
- Do not use sharp implements to remove the ice.

Danger of crushing:

- Do not hold the hinge when opening and closing the door. Fingers may get caught.

Symbols on the appliance:



The symbol can be located on the compressor. It refers to the oil in the compressor and indicates the following danger: Swallowing or inhaling can be fatal. This is only relevant for recycling. There is no danger in normal operation.

Please observe the specific information in the other sections:

	DANGER	identifies a situation involving direct danger which, if not obviated, may result in death or severe bodily injury.
	WARNING	identifies a dangerous situation which, if not obviated, may result in death or severe bodily injury.
	CAUTION	identifies a dangerous situation which, if not obviated, may result in minor or medium bodily injury.
	NOTICE	identifies a dangerous situation which, if not obviated, may result in damage to property.
	Note	identifies useful information and tips.

3 Controls and displays

3.1 Operating and control elements

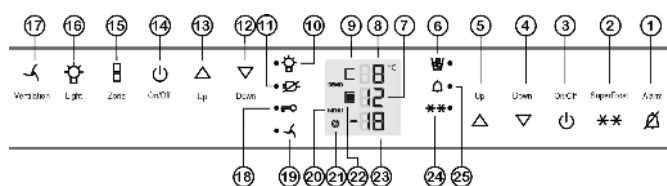

Fig. 3

- | | |
|--|--|
| (1) Alarm button | (14) On/Off button, wine zone |
| (2) SuperFrost button | (15) Zone button |
| (3) On/Off button, freezer compartment | (16) Light button |
| (4) Down setting button, freezer compartment | (17) Fan button |
| (5) Up setting button, freezer compartment | (18) Child lock symbol |
| (6) IceMaker symbol | (19) Fan symbol |
| (7) Temperature display, lower wine zone | (20) Menu symbol |
| (8) Temperature display, upper wine zone | (21) HomeDialog symbol |
| (9) Upper wine compartment symbol | (22) Lower wine compartment symbol |
| (10) Light symbol | (23) Freezer compartment temperature display |
| (11) Power failure symbol | (24) SuperFrost symbol |

- (12) Down setting button, wine zone
- (13) Up setting button, wine zone
- (25) Alarm symbol

3.2 Temperature display

During normal operation, the display shows:

- the average wine-tempering temperature
- the highest freezing temperature

The freezer temperature display flashes if/when:

- You change the temperature setting
- The appliance is not cold enough after switching on
- The temperature rises by several degrees

The wine cooler temperature display flashes if/when:

- You change the temperature setting
- The set temperature is not reached after switching on
- The wine cooler temperature is too low/high

Stripes flash in the display if/when:

- The freezer temperature exceeds 0 °C.

The following displays indicate a fault. Possible causes and solutions: (see Malfunction).

- **F0** to **F9**
- **FE**
- The power failure symbol LED  flashes.

4 Putting into operation

4.1 Transporting the appliance



CAUTION

Risk of injury and danger of damage as a result of incorrect transport!

- ▶ Transport the appliance in a packed condition.
- ▶ Transport the appliance upright.
- ▶ Do not transport the appliance without assistance.



WARNING

Risk of injury due to broken glass!

In case of transport at an altitude of over 1500 m the glass panes of the door may break. The fragments have sharp edges and may cause serious injury.

- ▶ Take appropriate protective action.

4.2 Installing the appliance



WARNING

Fire hazard due to dampness!

If live parts or the mains lead become damp this may cause short circuits.

- ▶ The appliance is designed for use in enclosed areas. Do not operate the appliance outdoors or in areas where it is exposed to splash water or damp conditions.



WARNING

Risk of fire due to short circuit!

If the mains cable/connector of the appliance or of another appliance touch the rear of the appliance, the mains cable/connector may be damaged by the appliance vibrations, leading to a short circuit.

- ▶ Stand the appliance so that it is not touched by connectors or main cables.
- ▶ Do not plug the appliance or any others into sockets located near the rear of the appliance.



WARNING

Fire hazard due to refrigerant!

The refrigerant R 600a is environmentally friendly but flammable. Escaping refrigerant may ignite.

- ▶ Do not damage the piping of the refrigeration circuit.



WARNING

Fire hazard and danger of damage!

- ▶ Do not place appliances emitting heat e.g. microwaves, toasters etc. on the appliance!



WARNING

Blocked ventilation openings pose a risk of fire and damage!

- ▶ Always keep the ventilation openings clear. Always ensure that the appliance is properly ventilated!

NOTICE*

Risk of damage due to condensate!

If your appliance is not a Side-by-Side (SBS) appliance:

- ▶ do not install the appliance directly alongside a further refrigerator/freezer.

- In the event that the appliance is damaged, contact the supplier immediately before connecting to the mains.
- The floor at the site must be flat and level.
- Do not install the appliance in a location where it is exposed to direct radiation of the sun, next to a cooker, heater and similar.
- The appliance may be moved only when it is empty.
- The surface supporting the appliance must be at the same level as the surrounding floor.
- Do not install the appliance without assistance.
- The more R 600a refrigerant there is in the appliance, the larger the room in which the appliance is standing needs to be. In rooms that are too small, a flammable mix of gas and air may be created if there is a leak. According to the EN 378 standard, every 11 g of R 600a refrigerant requires at least 1 m³ space in the room for the appliance. The amount of refrigerant in your appliance is on the type plate inside the appliance.
- ▶ Detach the connecting cable from the rear of the appliance, removing the cable holder at the same time because otherwise there will be vibratory noise!
- ▶ Remove the protective film from the outside of the appliance.

Putting into operation

NOTICE

The stainless steel doors are provided with a high-quality surface coating and must not be treated using the accompanying care product.



Otherwise the surface coating will be affected.

- ▶ Wipe the coated **door surfaces** using a soft, clean cloth only.
- ▶ Apply a stainless steel cleaner only to the **stainless steel side walls** evenly, wiping with the grain. Subsequent cleaning becomes easier as a result.
- ▶ Wipe **side walls with a paint finish** using a soft, clean cloth only.

- ▶ Remove the protective film from the decorative trims and drawer fronts.
- ▶ Remove all transit supports.
- ▶ Dispose of packaging material (see 4.6).
- ▶ Align the appliance so that it stands firmly and on a level by applying the accompanying spanner to the adjustable-height feet (A) and using a spirit level.
- ▶ Then support the door: Extend the adjustable foot at the turn hinge (B) until it rests on the floor and then make a further 90° turn.*

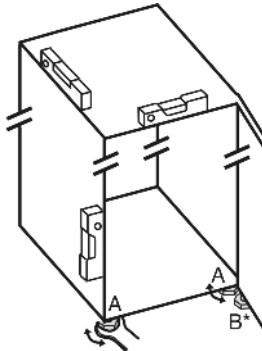

When a Side-by-Side appliance (S...) is fitted together with a second appliance (as a SBS combination):

- ▶ Proceed according to the Side-by-Side combined fridge-freezer installation instructions. (Accessories bag of the SBS freezer/appliance with freezer compartment)*

Note

- ▶ Clean the appliance (see 6.3).

If the appliance is installed in a very damp environment, condensate may form on the outside of the appliance.

- ▶ Always see to good ventilation at the installation site.

4.3 Changing over the door hinges

You can change over the door hinges if necessary.

NOTICE

Risk of damage to side-by-side appliances due to condensation!

When a side-by-side appliance (S...) is fitted together with a second appliance (as a SBS combination), the door hinges must remain as delivered.

- ▶ Do not change over the door hinges.

Ensure that the following tools are to hand:

- Torx® 25
- Torx® 15
- Screwdriver
- Cordless screwdriver, if necessary
- Second person for fitting work, if needed
- Accompanying Allen key size 2*

4.3.1 Detaching the upper soft stop mechanism

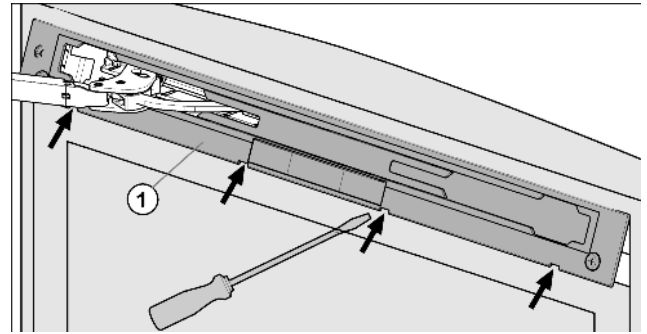

Fig. 4

- ▶ Open the upper door.

NOTICE

Risk of damage!

If the door seal is damaged, the door may fail to close properly and the cooling will be inadequate.

- ▶ Do not damage the door seal with the screwdriver!

- ▶ Disengage and remove the faceplate Fig. 4 (1) using a flat-blade screwdriver.
- ▷ The faceplate is attached over the soft stop bracket.

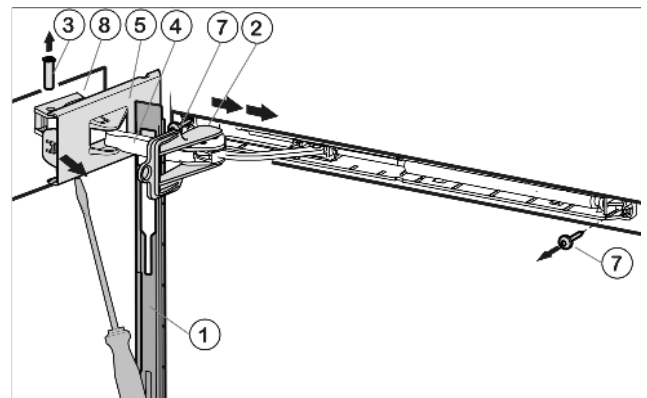

Fig. 5

- ▶ Slide the faceplate forwards over the soft stop bracket Fig. 5 (4) in the direction of the appliance.
- ▶ Snap the safety lock Fig. 5 (2) into the oblong hole.
- ▷ The safety lock prevents the hinge from snap-closing.
- ▶ Using a screwdriver, detach the cover Fig. 5 (5) on the hinge side as far as the first detent.
- ▷ The pin becomes visible.
- ▶ Press the pin Fig. 5 (3) out from underneath.
- ▶ Press the soft stop bracket Fig. 5 (4) towards the door.
- ▶ Fully detach the cover Fig. 5 (5) on the hinge side and remove it.
- ▶ Remove the faceplate Fig. 5 (1).
- ▶ Using a screwdriver, detach the cover on the handle side Fig. 6 (6) and draw it outwards for removal.

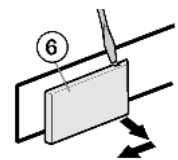

Fig. 6

- ▶ Unscrew the soft stop unit (2x Torx® 15) Fig. 5 (7).
- ▶ Pull the soft stop unit out a little, push it in the direction of the handle side and swing it out.
- ▶ Set the soft stop unit aside.

- ▶ Unscrew the bearing element *Fig. 5 (8)*, turn it 180° and transfer it to the opposite side. Possibly make preliminary holes with a bradawl or use a cordless screwdriver.

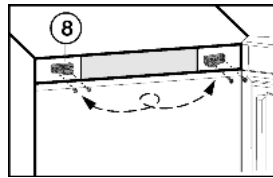

Fig. 7

4.3.2 Detaching the upper door

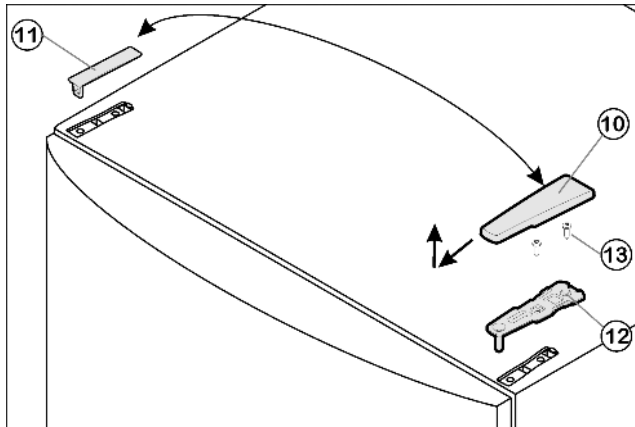

Fig. 8

- ▶ Close the upper door.
- ▶ Pull off the cover *Fig. 8 (10)* forwards and upwards.
- ▶ Lift off the cover *Fig. 8 (11)*.

CAUTION

- Risk of injury if the door tips!
- ▶ Take good hold of the door.
 - ▶ Set down the door carefully.

- ▶ Unscrew the upper turn hinge *Fig. 8 (12)* (2x Torx® 25) *Fig. 8 (13)* and lift it off.
- ▶ Lift off the upper door and set it aside.

4.3.3 Detaching the lower soft stop mechanism

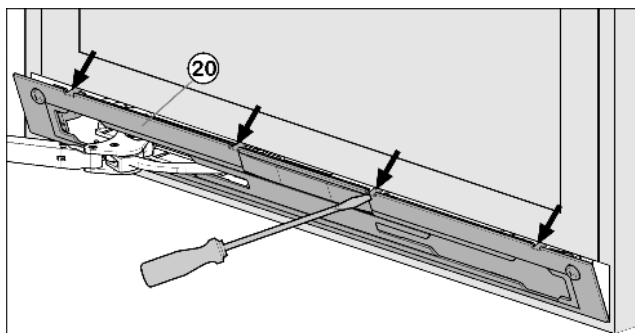

Fig. 9

- ▶ Open the lower door.

NOTICE

- Risk of damage!
- If the door seal is damaged, the door may fail to close properly and the cooling will be inadequate.

- ▶ Do not damage the door seal with the screwdriver!
- ▶ Disengage and remove the faceplate *Fig. 9 (20)* using a flat-blade screwdriver.
- ▷ The faceplate is attached over the soft stop bracket.

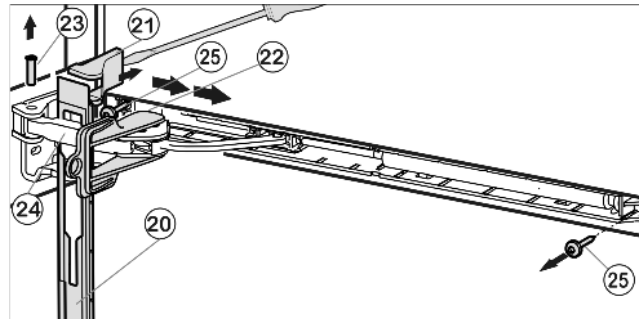

Fig. 10

- ▶ Slide the faceplate forwards over the soft stop bracket *Fig. 10 (24)* in the direction of the appliance.
- ▶ Snap the safety lock *Fig. 10 (22)* into the oblong hole.
- ▷ The safety lock prevents the hinge from snap-closing.
- ▶ Using a screwdriver, lift off the cover *Fig. 10 (21)* from the outside and remove it in an outward direction.
- ▶ If necessary, tip the appliance backwards with the assistance of a second person.
- ▶ Press the pin *Fig. 10 (23)* out from underneath.
- ▶ Press the soft stop bracket *Fig. 10 (24)* towards the door.
- ▶ Remove the faceplate *Fig. 10 (20)*.
- ▶ Unscrew the entire soft stop unit (2x Torx® 15) *Fig. 10 (25)*.
- ▶ Pull the soft stop unit out a little, push it in the direction of the handle side and swing it out.
- ▶ Set the soft stop unit aside.

4.3.4 Detaching the lower door

- ▶ Close the lower door.
- ▶ Draw the middle bearing pin *Fig. 11 (32)* together with the washer *Fig. 11 (34)* out of the turn hinge and lower door.
- ▶ Remove the plastic cap *Fig. 11 (33)*.

CAUTION

- Risk of injury if the door tips!
- ▶ Take good hold of the door.
 - ▶ Set down the door carefully.

- ▶ Open the lower door.
- ▶ Unscrew the middle turn hinge (2x Torx® 25). *Fig. 11 (31)*
- ▶ Lift off the lower door and set it aside.

4.3.5 Transferring the middle bearing elements

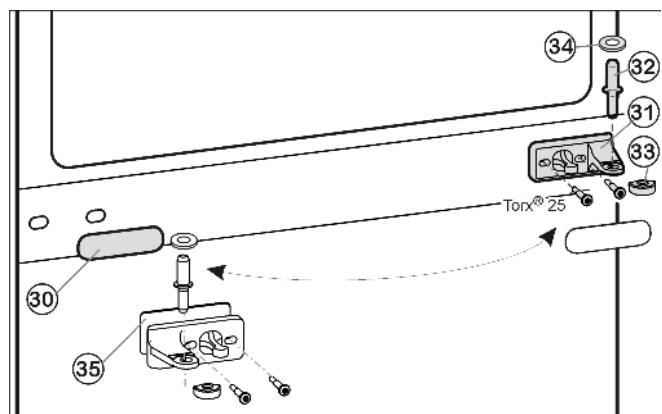

Fig. 11

- ▶ Carefully detach the cover panel *Fig. 11 (30)*.
- ▶ Turn the middle turn hinge *Fig. 11 (31)* with the washer *Fig. 11 (35)* through 180° and screw it **firmly** into place on the new hinge side (**with 4 Nm**).
- ▶ Turn the cover panel *Fig. 11 (30)* through 180° and snap it into place again on the new handle side.

Putting into operation

4.3.6 Distinguishing between bearing elements

Some appliances are height-adjustable, as can be noted from the bearing pin in the lower turn hinge:

► For appliances **without height adjustment**, continue with item (see 4.3.7).

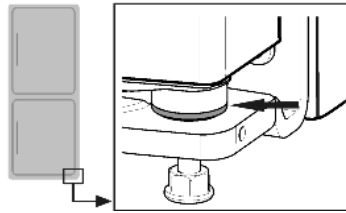

► For appliances **with height adjustment**, continue with item (see 4.3.8).

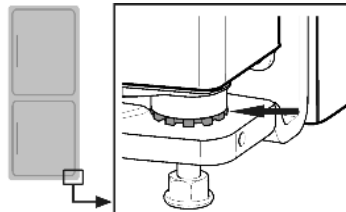

4.3.7 Transferring the lower bearing elements

For appliances without height adjustment

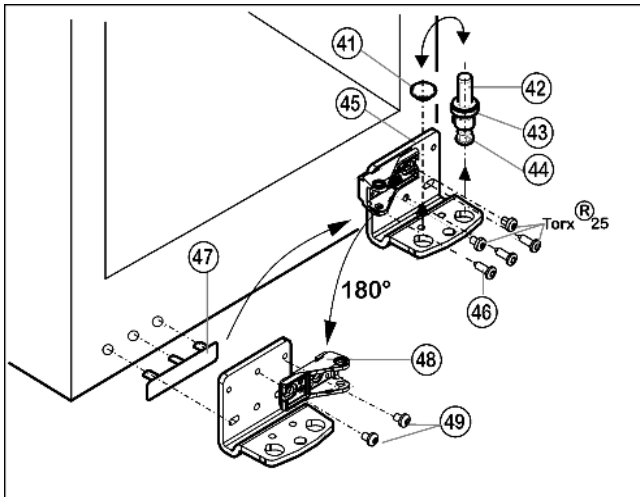

Fig. 12

- Lift out the bearing pin Fig. 12 (42) together with washer Fig. 12 (43) and adjustable-height foot Fig. 12 (44).
- Lift out the stopper Fig. 12 (41).
- Unscrew Fig. 12 (46) the turn hinge Fig. 12 (45).
- Unscrew the bearing element Fig. 12 (48), turn it through 180° and screw it firmly into place again inside
- Carefully lift off the cover on the handle side Fig. 12 (47) and transfer it to the opposite side.
- Screw the bottom turn hinge Fig. 12 (45) firmly into place (with 4 Nm) on the new hinge side, possibly using a cordless screwdriver.
- Re-insert the stopper Fig. 12 (41) into the other hole.
- Re-insert the bearing pin Fig. 12 (42) together with the washer and adjustable-height foot. In so doing, pay attention that the locating lug points backwards

4.3.8 Transferring the lower bearing elements

For appliances with height adjustment

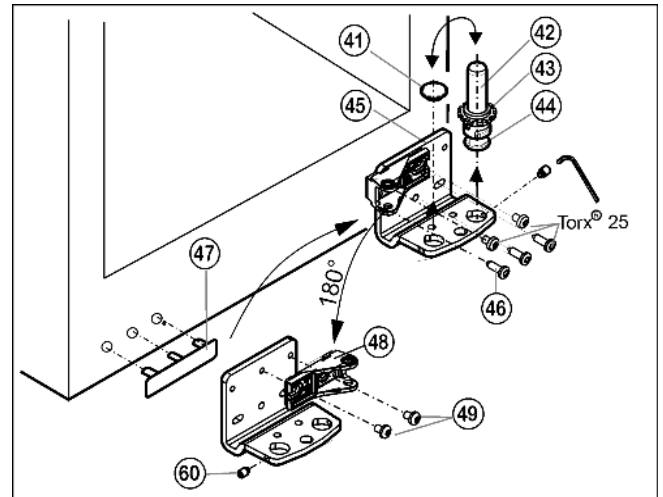

Fig. 13

- Using the accompanying Allen key, unscrew the threaded pin Fig. 13 (60) by about 1 turn.
- Turn and lift out the bearing pin Fig. 13 (42) together with the washer Fig. 13 (43) and adjustable-height foot Fig. 13 (44).
- Lift out the stopper Fig. 13 (41).
- Unscrew Fig. 13 (46) the turn hinge Fig. 13 (45).
- Fully unscrew the threaded pin Fig. 13 (60) and screw it in on the opposite side, at the turn hinge, until it is flush outside with the turn hinge.
- Unscrew the bearing element Fig. 13 (48), turn it through 180° and screw Fig. 13 (49) it firmly back into place.
- Re-insert the stopper Fig. 13 (41) into the other hole.
- Carefully lift off the cover on the handle side Fig. 13 (47) and transfer it to the opposite side.
- Screw the turn hinge Fig. 13 (45) firmly into place on the new hinge side, possibly using a cordless screwdriver (with 4 Nm).
- Screw the bearing pin Fig. 13 (42) into place again, complete with washer and adjustable-height foot.
- Tighten the threaded pin Fig. 13 (60).

4.3.9 Transferring the handles

On both the top and bottom doors:

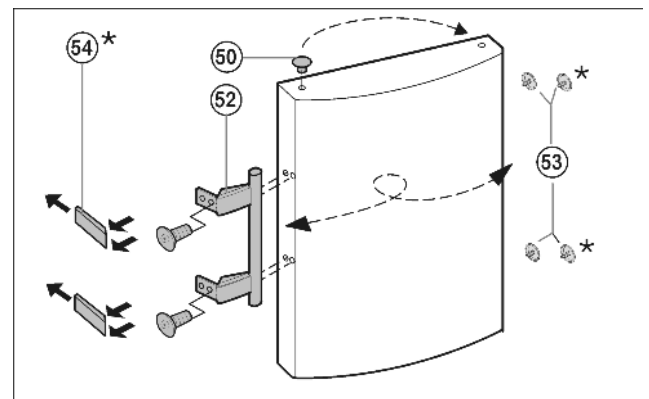

Fig. 14

- Lift the stopper Fig. 14 (50) out of the door bearing bush and transfer it.
- Detach door handle Fig. 14 (52), stopper Fig. 14 (53) and pressure plates Fig. 14 (54) and transfer to the opposite side.
- When fitting the pressure plates on the opposite side, make sure they snap properly into place.*

4.3.10 Fitting the lower door

- Place the door from above onto the lower bearing pin Fig. 13 (42).
- Close the door.

- ▶ Place the plastic cap *Fig. 11 (33)* back onto the middle turn hinge *Fig. 11 (31)*.
- ▶ On the new hinge side, pass the middle bearing pin *Fig. 11 (32)* through the middle turn hinge *Fig. 11 (31)* into the lower door.
- ▶ Attach the washer *Fig. 11 (34)* to the middle bearing pin *Fig. 11 (32)*.

4.3.11 Fitting the lower soft stop mechanism

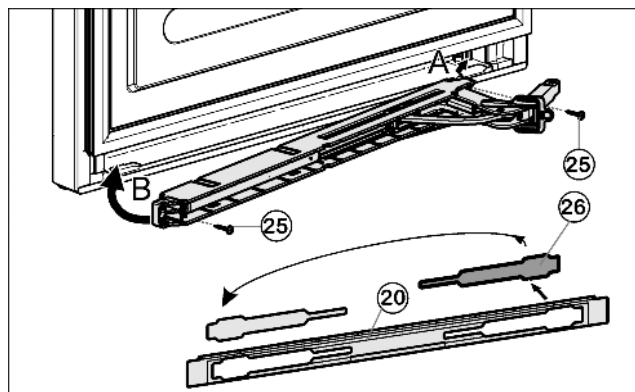

Fig. 15

- ▶ Remove the cover *Fig. 15 (26)* from the faceplate *Fig. 15 (20)* and re-insert it at the other side.
- ▶ Engage the soft stop unit with the joint pointing to the hinge side (A) and swivel into place (B).
- ▷ The screw holes at the left and right have to register.
- ▶ Screw the soft stop unit firmly into place (2 mal Torx® 15) *Fig. 15 (25)*.

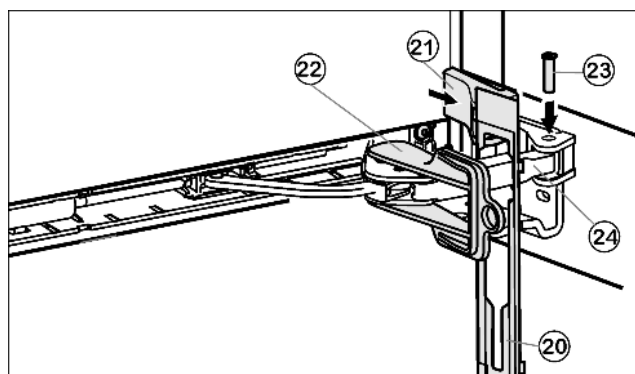

Fig. 16

- ▶ Attach the faceplate *Fig. 16 (20)* to the soft stop bracket so that the catches face forwards and the front faces the appliance.
- ▶ Draw the soft stop bracket *Fig. 16 (24)* towards the bearing element and insert the pin *Fig. 16 (23)* from above so that the square is seated in the depression.
- ▶ Attach and engage the cover *Fig. 16 (21)*.
- ▷ Pay attention that the cover fits properly so that the door closes properly and the pin is secured.
- ▶ Twist the safety lock *Fig. 16 (22)* for removal.
- ▶ Snap the faceplate *Fig. 16 (20)* onto the door.
- ▶ Close the lower door.

4.3.12 Fitting the upper door

- ▶ Place the upper door on the middle bearing pin *Fig. 11 (32)*.
- ▶ Insert the upper turn hinge *Fig. 8 (12)* in the door on the new hinge side.
- ▶ Screw the upper turn hinge firmly into place (with 4 Nm) (2xTorx® 25) *Fig. 8 (13)*. Possibly make preliminary holes with a bradawl or use a cordless screwdriver.
- ▶ Snap the cover *Fig. 8 (11)* and cover *Fig. 8 (10)* into place at the opposite side.
- ▶ Leave the upper door open.

4.3.13 Fitting the upper soft stop mechanism

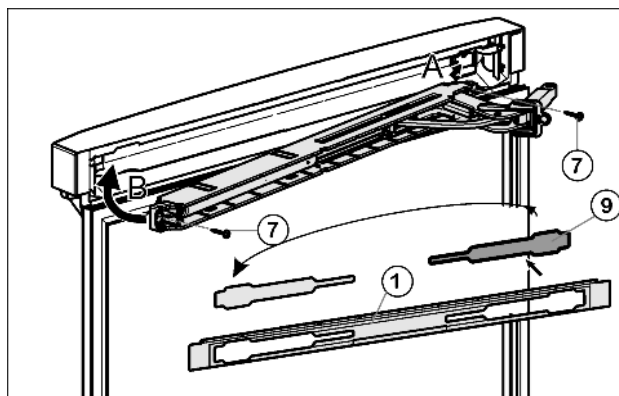

Fig. 17

- ▶ Remove the cover *Fig. 17 (9)* from the faceplate *Fig. 17 (1)* and re-insert it at the other side.
- ▶ Engage the upper soft stop unit with the joint on the hinge side (A) and swivel into place (B).
- ▷ The screw holes at the left and right have to register.
- ▶ Screw the soft stop unit firmly into place (2 mal Torx® 15) *Fig. 17 (7)*.

Note

- ▶ Keep to the correct order. First attach the panel over the soft stop bracket, then the cover.

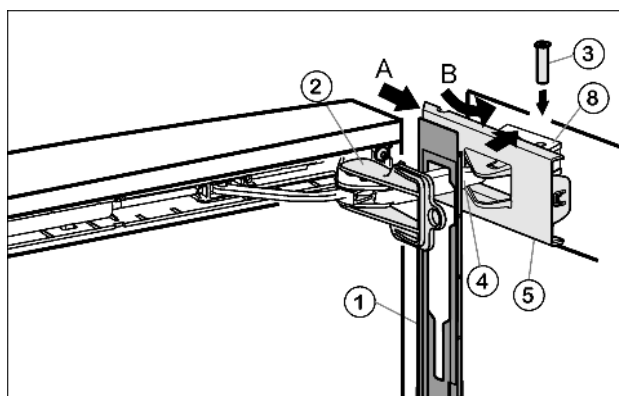

Fig. 18

- ▶ Attach the faceplate *Fig. 18 (1)* to the soft stop bracket *Fig. 18 (4)* so that the catches face inwards and the front faces the appliance.
- ▶ Slide on the cover *Fig. 18 (5)* from the outside (A) and swivel it over the bearing element *Fig. 18 (8)* (B).
- ▶ Attach the cover *Fig. 18 (5)* and engage it as far as the first detent.
- ▷ The openings for the pin are on top of one another after the soft stop bracket has been positioned.
- ▶ Draw the soft stop bracket *Fig. 18 (4)* towards the bearing element and insert the pin *Fig. 18 (3)* from above so that the square is seated in the depression.
- ▶ Now completely snap the cover *Fig. 18 (5)* onto the bearing element *Fig. 18 (8)*.
- ▷ Pay attention that the cover fits properly so that the door closes properly and the pin is secured.
- ▶ Twist the safety lock *Fig. 18 (2)* for removal.
- ▶ Snap the faceplate *Fig. 18 (1)* onto the door.
- ▶ Turn the cover *Fig. 6 (6)* through 180°, attach and engage it on the handle side.

4.3.14 Aligning the doors

- ▶ If necessary, align the doors to the appliance housing by way of the two oblong holes in the bottom turn hinge *Fig. 13 (45)* and middle turn hinge *Fig. 11 (31)*. To do so, unscrew the middle screw in the bottom turn hinge *Fig. 13 (45)*.

Putting into operation



WARNING

Risk of injury due to the door dropping out!
If the bearing parts are not screwed into place firmly enough, the door may drop out. This may lead to severe injuries. What is more, the door may not close and therefore the appliance may fail to cool properly.

- ▶ Screw the turn hinges firmly into place with 4 Nm.
- ▶ Check all of the screws and retighten if necessary.

4.4 Water connection



WARNING

Danger of electric shock!

- ▶ Disconnect the appliance by unplugging it before you connect it to the water line.
- ▶ Shut off the water supply before you connect the water feed lines of the IceMaker.
- ▶ The connection to the drinking water system may be carried out only by a qualified gas fitter and plumber.



WARNING

Risk of poisoning!

- ▶ The water quality has to comply with the drinking water ordinance of the respective country (e.g. 98/8)
- ▶ Connect to the drinking water supply only.
- ▶ The IceMaker serves exclusively for making ice cubes in household quantities and has to be operated with water suitable for the purpose.

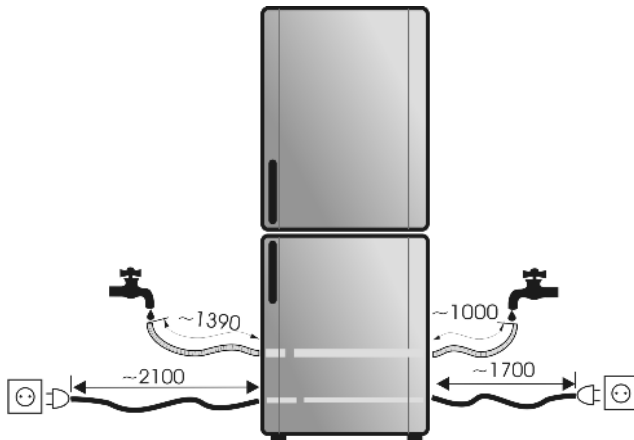

Fig. 19

- The water pressure has to be between 0.15 MPa and 0.6 MPa (1.5 bar - 6 bar).
- The water supply to the appliance must be via a cold water pipe which withstands the operating pressure and complies with the hygiene regulations.
Use the accompanying stainless steel hose (1.5 m). Do not reuse old hoses. A 3 m hose is available from the customer service department and has to be fitted by an expert.
In the hose connecting piece is a sieve with seal.
- Between the hose and the domestic water connection there has to be a stopcock to interrupt the water supply in case of need.
- All the fixtures and fittings used for water supply have to comply with the applicable regulations of the respective country.
- Do not damage or kink the water inlet pipe when installing the appliance.

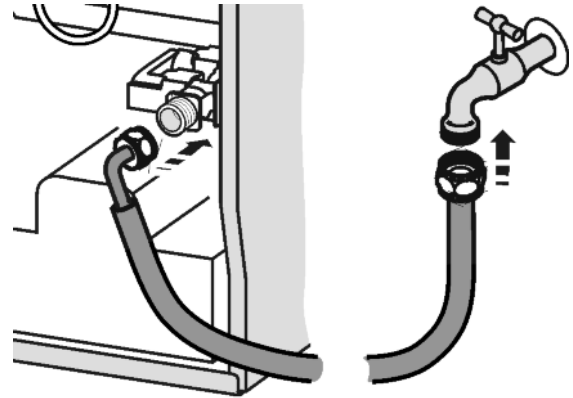

Fig. 20

- ▶ Connect the straight part of the accompanying stainless steel hose to the stopcock.

The solenoid valve is at the bottom back of the appliance. It has a metric R3/4 connecting thread.

- ▶ Connect the angled part of the stainless steel hose to the solenoid valve.

- ▶ Open the stopcock of the water supply and check that the entire water system is leakproof.
Before initial use:

- ▶ Have the water pipe bled of air by the proper expert.

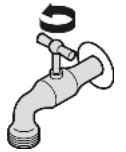

4.5 Insertion into a row of kitchen units

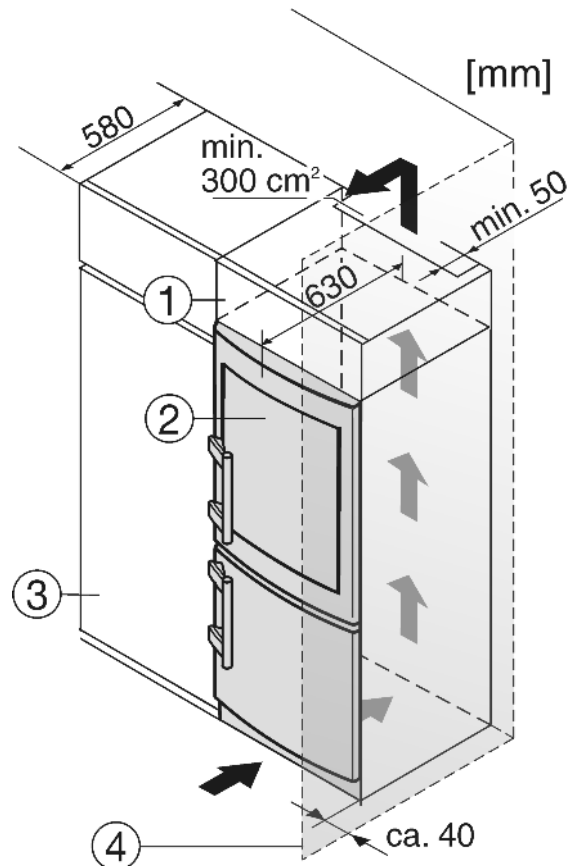

Fig. 21

- (1) Stack cabinet
- (2) Appliance
- (3) Kitchen cabinet
- (4) Wall

The appliance can be built into kitchen units. A top cupboard Fig. 21 (2) can be added above the appliance in order to bring the appliance Fig. 21 (1) up to the height of the fitted kitchen units.

When retrofitting with kitchen cabinets (max. depth 580 mm) the appliance can be installed directly next to the cabinet *Fig. 21 (3)*. The appliance door projects 34 mm from the front of the kitchen cabinet at the side and 50 mm at the centre of the appliance. This is so that it can be opened and closed easily.

Ventilation requirements:

- At the back of the stack cabinet there has to be a ventilation duct of at least 50 mm depth throughout the width of the stack cabinet.
- the larger the ventilation space, the more energy-saving the appliance is in operation.

If the appliance is installed with the hinges next to a wall *Fig. 21 (4)*, the distance between appliance and wall has to be at least 40 mm. This corresponds to the projection of the handle when the door is open.

4.6 Disposing of packaging



WARNING

Danger of suffocation due to packing material and plastic film!
▶ Do not allow children to play with packing material.

The packaging is made of recyclable materials:

- corrugated board/cardboard
- expanded polystyrene parts
- polythene bags and sheets
- polypropylene straps
- nailed wooden frame with polyethylene panel*

▶ Take the packaging material to an official collecting point.



4.7 Connecting the appliance

NOTICE

Failure to connect properly
Damage to the electronics.

- ▶ Do not use a standalone inverter.
- ▶ Do not use an energy saving plug.



WARNING

Failure to connect properly
Fire.

- ▶ Do not use an extension cable.
- ▶ Do not use distributor blocks.

The type of current (alternating current) and voltage at the installation site have to conform with the data on the type plate (see Appliance at a glance).

The socket must be properly earthed and fused. The tripping current for the fuse must be between 10 A and 16 A.

The socket must be easily accessible so that the appliance can be quickly disconnected from the supply in an emergency. It must be outside the area of the rear of the appliance.

- ▶ Check the electrical connection.
- ▶ Plug in the power plug.



4.8 Switching on the appliance

Note

- ▶ To switch on the entire appliance it is necessary only to switch on the freezer compartment.

Switch on the appliance approx. 2 hours before adding frozen food for the first time.

Do not load food to be frozen before the temperature display reads -18 °C.



4.8.1 Switching on the freezer compartment

- ▶ Press On/Off button, freezer compartment *Fig. 3 (3)*.
- ▷ The temperature display of the multi-temperature wine zone and the alarm symbol flash until the set temperature is reached.
- ▷ The temperature display of the freezer compartment and the alarm symbol flash until the temperature is sufficiently low. If the temperature is above 0 °C, dashes flash. If it is below, the current temperature flashes.
- ▷ If "DEMO" is displayed, demo mode is activated. Please contact the after sales service.

5 Control

5.1 Brightness of the temperature display

You can adjust the brightness of the temperature display to the light conditions of the room in which the appliance is installed.

The function works with the door closed and is not relevant for appliances with a concealed screen.

5.1.1 Adjusting the brightness

The brightness is adjustable between **h0** (no illumination) and **h5** (maximum luminosity).

- ▶ To activate the setting mode: press the SuperFrost button *Fig. 3 (2)* for about 5 s.

▷ The display indicates **c**.

▷ The menu symbol *Fig. 3 (20)* shines.

- ▶ Using the Up setting button, freezer compartment *Fig. 3 (5)* or Down setting button, freezer compartment *Fig. 3 (4)*, select **h**.

- ▶ To confirm: briefly press the SuperFrost button *Fig. 3 (2)*.

- ▶ To make the display brighter: press Up button, freezer compartment *Fig. 3 (5)*.

- ▶ To make the display darker: press Down button, freezer compartment *Fig. 3 (4)*.

- ▶ To confirm: press SuperFrost button *Fig. 3 (2)*.

▷ The brightness is adjusted to the new value.

- ▶ To deactivate the set-up mode: press On/Off button, freezer compartment *Fig. 3 (3)*.

-or-

- ▶ Wait for 5 minutes.

▷ The temperature is indicated again in the temperature display.



5.2 Child proofing

The child-proofing function enables you to make sure that the appliance is not inadvertently switched off by playing children.



5.2.1 Setting the child lock function

- ▶ To activate the setting mode: press SuperFrost button *Fig. 3 (2)* for about 5 s.

▷ **c** flashes on the display.

▷ The menu symbol *Fig. 3 (20)* shines.

- ▶ Briefly press the SuperFrost button *Fig. 3 (2)* to confirm.

Control

When **cl** is indicated in the display:

- ▶ To activate the child lock, briefly press the SuperFrost button *Fig. 3 (2)*.



- ▷ The LED of the child lock symbol *Fig. 3 (18)* shines. **cl** flashes in the display.

When **cl** is indicated in the display:

- ▶ to deactivate the child lock, briefly press the SuperFrost button *Fig. 3 (2)*.
- ▷ The LED of the child lock symbol *Fig. 3 (18)* goes out. **cl** flashes in the display.
- ▶ To deactivate the set-up mode: press On/Off button, freezer compartment *Fig. 3 (3)*.

-or-

- ▶ Wait for 5 minutes.
- ▷ The temperature is indicated again in the temperature display.

5.3 Door alarm

For the fridge and freezer compartments
An audible warning sounds if the door is open for longer than 60 seconds.

The audible warning stops automatically when the door is closed.



5.3.1 Muting the door alarm

- ▷ The temperature is indicated in the display. The display changes to the normal temperature display.

5.4 Temperature alarm

The audible alarm sounds if the freezer temperature is not cold enough.

At the same time, the temperature display and LED of the alarm symbol *Fig. 3 (25)* flashes.



The cause of the temperature being too high may be:

- too much warm ambient air flowed in when rearranging and removing food
- power failure for some time
- the appliance is faulty

The audible alarm is automatically silenced, the alarm symbol *Fig. 3 (25)* goes out and the temperature display stops flashing when the temperature is sufficiently cold/warm again.

If the alarm status persists: (see Malfunction).

Note

Food may be spoiled if the temperature is not cold enough.

- ▶ Check the quality of the food. Do not consume spoiled food.

5.4.1 Muting the temperature alarm

The audible alarm can be muted. When the temperature is sufficiently cold again, the alarm function is active again.

- ▶ Press alarm button *Fig. 3 (1)*.
- ▷ The audible alarm is silenced.

5.5 Freezer compartment

You can store frozen food, make ice cubes and freeze fresh food in the freezer compartment.

5.5.1 Freezing food

The rating plate indicates the maximum quantity of fresh food you can freeze within 24 hours (see Appliance at a glance) under "Freezing capacity ... kg/24h".

The maximum load of frozen food for the drawers is 25 kg each and for the shelves 35 kg each.



CAUTION

Risk of injury due to broken glass!

Bottles and cans containing drinks may burst when being frozen. This applies particularly to sparkling drinks.

- ▶ Do not freeze bottles and cans containing drinks!

In order that the food is rapidly frozen through to the core, do not exceed the following quantities per pack:

- Fruit, vegetables up to 1 kg
- Meat up to 2.5 kg

- ▶ Pack the food in portions in freezer bags, reusable plastic, metal or aluminium containers.

5.5.2 Thawing food

- in the refrigerator compartment
- in a microwave oven
- in a conventional or fan oven
- at room temperature

- ▶ Food once thawed should be re-frozen only in exceptional cases.

5.5.3 Setting the temperature in the freezer compartment

The appliance is pre-set for normal operation.

The temperature can be set between -16 °C and -26 °C, the recommended temperature is -18 °C.

- ▶ To set the temperature higher: press Up button, freezer compartment *Fig. 3 (5)*.
- ▶ To set the temperature lower: press Down button, freezer compartment *Fig. 3 (4)*.

- ▷ When the button is pressed the first time, the previous value is indicated in the temperature display of the freezer compartment.
- ▶ To change the temperature in 1 °C steps: briefly press the button.

-or-

- ▶ To change the temperature continuously: hold down the button.

- ▷ The value is displayed flashing during the setting operation.
- ▷ The actual temperature is displayed approx. 5 seconds after the button is last pressed. The temperature gradually adjusts to the new value.

5.5.4 SuperFrost

With this function you can freeze fresh food quickly through to the core. The appliance operates with maximum refrigeration. The noise of the refrigeration unit may be temporarily louder as a result. **

The maximum amount of fresh food which can be frozen in 24 h is indicated on the type plate under "freezing capacity ... kg/24h". This amount varies according to the model and climate rating.*

You have to activate SuperFrost in good time, depending on how much fresh food is to be frozen: about 6 hours before placing the food inside in case of small amounts and about 24 hours in advance in case of the maximum amount of food to be frozen.

Wrap produce and spread it out as far as possible. Do not allow produce to be frozen to touch produce that is already frozen to prevent the latter thawing.

You do not have to activate SuperFrost in the following cases:

- when placing frozen food in the freezer
- when freezing up to approx. 2 kg fresh food daily

Freezing with SuperFrost

- ▶ Briefly press the SuperFrost button *Fig. 3 (2)* once.
- ▷ The LED of the SuperFrost symbol *Fig. 3 (24)* shines.
- ▷ The freezing temperature drops, the appliance operates with the maximum cooling capacity.
 - For a smaller quantity of produce to be frozen:
 - ▶ wait approx. 6 h.
 - ▶ Place wrapped produce in the top drawers.
 - For the maximum quantity of produce to be frozen:
 - ▶ wait approx. 24 h.
 - ▶ Remove top drawers and place produce directly on the top shelves.
- ▷ SuperFrost is automatically deactivated. Depending on the quantity placed inside, after 30 h at the earliest, 65 h at the latest.
- ▷ The LED on the SuperFrost symbol *Fig. 3 (24)* extinguishes once freezing is completed.
 - ▶ Place produce in the drawers and push the latter back in again.
 - ▷ The appliance continues to operate in the energy-saving, normal mode.

5.5.5 Drawers

Note

The energy consumption increases and the cooling performance decreases if there is insufficient ventilation.

For appliances with NoFrost:

- ▶ Leave the bottom drawer in the appliance!
- ▶ Always keep the air slits of the fan free at the rear wall!

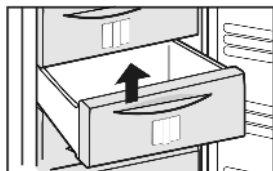

- ▶ To store frozen food directly on the shelves: pull the drawer forwards and lift it out.

5.5.6 Shelves

- ▶ To remove the shelf: lift up at the front and pull out.
- ▶ To put the shelf back: simply push in as far as it will go.

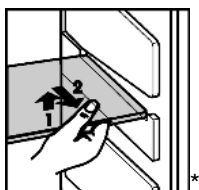

5.5.7 VarioSpace

Apart from being able to remove the drawers, you can also remove the shelves, creating space for large items of frozen food. Poultry, meat, large pieces of game and high bakery products can be frozen in one piece and prepared.

- ▶ The maximum load of frozen food for the drawers is 25 kg each and for the shelves 35 kg each.

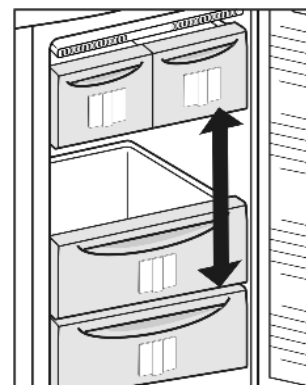

5.5.8 Information system



Fig. 22

- (1) Ready-made meals, ice cream
- (2) Pork, fish
- (3) Fruit, vegetables
- (4) Sausages, bread
- (5) Game, mushrooms
- (6) Poultry, beef/veal

The figures indicate the storage time in months for several types of frozen food in each case. Storage times given are guide times.

5.5.9 Cold storage accumulators

The cold storage accumulators prevent the temperature from rising too fast in the event of power failure.

Using cold storage accumulators

- ▶ Place the cold storage accumulators in the top freezer compartment to save space.
- ▶ Place the frozen cold storage accumulators on the frozen food in the upper front area of the freezer compartment.

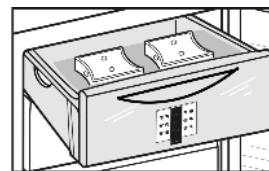

5.5.10 IceMaker

The IceMaker is in the top drawer of the freezer compartment. The drawer is marked "IceMaker".

Make certain that the following conditions are met:

- The appliance is level.
- The appliance is connected.
- The freezer compartment is switched on.
- The IceMaker is connected to the water supply.

Switching on the IceMaker

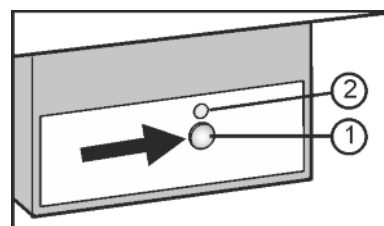

Fig. 23

- ▶ Pull out the drawer.
- ▶ Press the On/Off button *Fig. 23 (2)* so that the LED *Fig. 23 (1)* shines.
- ▶ Push in the drawer.
- ▷ The LED of the IceMaker symbol *Fig. 3 (6)* shines.

Control

Note

- ▶ The IceMaker produces ice cubes only if the drawer is fully closed.

Producing ice cubes

The production capacity depends on the freezer temperature. The lower the temperature, the more ice cubes can be produced in a specific period.

The ice cubes drop from the IceMaker into the drawer. When a certain filling level has been reached, no further ice cubes are produced. The IceMaker does not fill the drawer right up to the brim.

If large quantities of ice cubes are needed, the complete IceMaker drawer can be exchanged for the adjacent drawer. When the drawer is closed, the IceMaker automatically recommences production.

Once the IceMaker has been switched on for the first time, it may take up to 24 hours until the first ice cubes are produced.

Note

When the appliance is used for the first time and if it has been out of use for a long time, particles may collect in the IceMaker and/or water conduit.

- ▶ Therefore do not use or consume the ice cubes made in the first 24 hours.

Setting the water intake time

The opening time of the IceMaker valve can be set if, for example, the water pressure in the pipe is too low or too high.

The water intake time can be set in stages from **E1** (short intake time) to **E8** (long intake time). The intake is preset at **E3**.

- ▶ To activate the setting mode: press the SuperFrost button *Fig. 3 (2)* for about 5 s.
- ▷ The display indicates **c**.
- ▷ The menu symbol *Fig. 3 (20)* shines.
- ▶ Using the Up setting button, freezer compartment *Fig. 3 (5)* and Down setting button, freezer compartment *Fig. 3 (4)* select **E**.
- ▶ To confirm: briefly press the SuperFrost button *Fig. 3 (2)*.
- ▶ To increase the water intake time: press the Up setting button, freezer compartment *Fig. 3 (5)*.
- ▶ To reduce the water intake time: press the Down setting button, freezer compartment *Fig. 3 (4)*.
- ▶ To confirm: press the SuperFrost button *Fig. 3 (2)*.
- ▶ To deactivate the setting mode: press the On/Off button, freezer compartment *Fig. 3 (3)*.



-or-

- ▶ Wait for 5 minutes.

- ▷ The temperature is indicated again in the temperature display.

Switching off the IceMaker

If no ice cubes are needed, the IceMaker can be switched off independently of the freezer compartment.

When the IceMaker is switched off, the IceMaker drawer can also be used for freezing and storing food.

- ▶ Press the On/Off button for about 1 second until the LED goes out.
- ▷ The LED of the IceMaker symbol *Fig. 3 (6)* goes out.
- ▶ Clean the IceMaker.
- ▷ This ensures that no water or ice remains in the IceMaker.

5.6 Wine zone

You can bring your wines to the ideal drinking temperature slowly and gradually in the wine zone.

5.6.1 Storing wine bottles

- 41 Bordeaux bottles(0,75 l) can be stored in the wine zone.
- ▶ Store white wine only in one compartment and red wine only in the other, since both compartments can be set to independent temperatures.
- ▶ If possible, lay bottles of the same type of wine side by side on the same grid shelf.
- ▶ Rearrange bottles as seldom as possible.
- ▶ Stored open bottles on the folded down wooden grid shelf.
- ▶ To fold down the wooden grid shelf: press the lock under the trim sideways.
- ▷ The wooden grid shelf folds down.

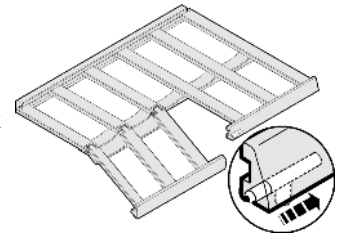

5.6.2 Setting the temperature in the wine zone

The appliance is pre-set for normal operation. The temperature can be set from 20 °C to 5 °C, the recommended temperatures are 8 °C to 12 °C.

The wine zone is divided into two wine compartments, which can be set to different temperatures, as needed.

- ▶ To select the wine compartment: press the zone button *Fig. 3 (15)*.
- ▷ The selected wine compartment is indicated in the temperature display.



- ▶ To set the temperature warmer: press the Up setting button, wine zone *Fig. 3 (13)*.
- ▶ To set the temperature colder: press the Down setting button, wine zone *Fig. 3 (12)*.
- ▷ The first time the button is pressed, the previous value is indicated in the temperature display, upper wine zone *Fig. 3 (8)* or in the temperature display, lower wine zone *Fig. 3 (7)*.
- ▶ To change the temperature in 1 °C steps: briefly press the button.

-or-

- ▶ To change the temperature continuously: hold down the button.
- ▷ During setting the new value is displayed flashing.
- ▷ The actual temperature is displayed about 5 s after the last press of a button. The temperature slowly adjusts to the new value.

5.6.3 Fan

When the fan runs, the relative humidity in the interior increases so that the cork does not dry out.

When the fan is activated, the energy consumption increases. To save energy, the fan switches off automatically when the door is open.

Switching on the fan



- ▶ Briefly press the fan button *Fig. 3 (17)*.



- ▷ The LED of the fan symbol shines.

Switch off the fan

- ▶ Briefly press the fan button *Fig. 3 (17)*.
- ▷ The LED of the fan symbol is dark.
- ▷ The fan runs only when this is necessary for temperature control. The humidity is low.

5.6.4 Dim mode

For glazed door models you can set the dim mode of the light, i.e. the intensity with which the light is to shine after the door has closed.

Setting the dim mode

Note

▶ When the dim mode is deactivated, the light becomes slowly darker after the door has closed and then goes out.

- ▶ Briefly press the Light button *Fig. 3 (16)*.
- ▷ The Light button *Fig. 3 (16)* shines. The dim mode is activated.

The settings apply to all wine compartments.

- ▶ For a brighter light adjustment: press Light button *Fig. 3 (16)* and Up setting button, wine zone *Fig. 3 (13)* at the same time.
- ▶ For a darker light adjustment: press Light button *Fig. 3 (16)* and Down setting button, wine zone *Fig. 3 (12)* at the same time.

5.6.5 Labels

You can note down on the labels the type of wine stored in the respective compartment. Additional labels can be obtained from your specialist dealer.

Labelling

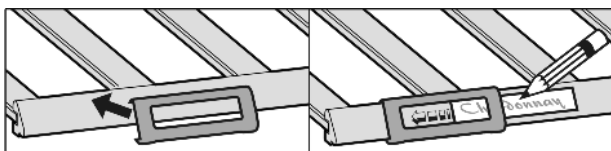

5.6.6 Wooden shelf

Pay attention that the wooden shelf does not get caught on the rear hook.

- ▶ To remove the folding wooden shelf: lift it off the pull-out rail and draw it forwards.
- ▶ To insert the wooden folding shelf: slide it under the rear hook and press onto the rails so that they audibly snap into place.
- ▶ To remove lower wooden shelf: pull it forwards at an angle and simultaneously raise it.
- ▶ To insert lower wooden shelf: slide it in over the stop on the intervening shelves up to the rear wall of the appliance and press it down.
- ▶ To insert other wooden shelves: place on the rails.

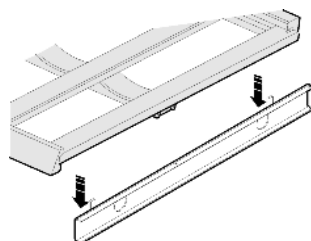
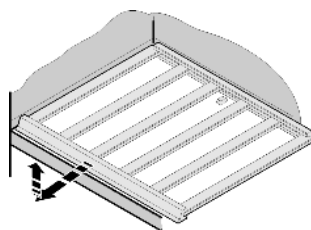
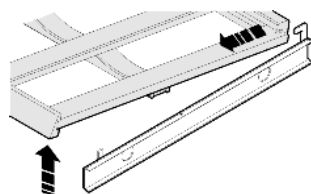

6 Maintenance

6.1 Replacing the activated charcoal filter

The activated charcoal filter ensures ideal air quality and should therefore be replaced annually. It can be ordered from a specialised dealer.

Each wine zone is equipped with an activated charcoal filter of its own.

- ▶ Take the activated charcoal filter by the grip.
- ▶ Turn the activated charcoal filter through 90° to the right or left *Fig. 24 (1)*.
- ▶ Remove *Fig. 24 (2)* the activated charcoal filter.
- ▶ Insert the new activated charcoal filter with the grip in an upright position.
- ▶ Turn the new activated charcoal filter through 90° to the right or left *Fig. 24 (1)* until it snaps into place.

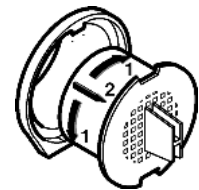

Fig. 24

6.2 Defrosting with NoFrost

The NoFrost system automatically defrosts the appliance.

Wine zone:

The defrost water evaporates due to the compressor heat. Drops of water on the rear wall are perfectly normal.

- ▶ Regularly clean the drain opening to allow the water to flow away (see 6.3).
- ▶ Clean the rubber lip (see 6.3).

Freezer compartment:

The moisture condenses on the evaporator, is periodically defrosted and evaporates.

- ▶ The appliance does not have to be manually defrosted.

6.3 Cleaning the appliance



WARNING

Risk of injury and damage as a result of hot steam! Hot steam can lead to burns and can damage the surfaces.

- ▶ Do not use any steam cleaners!

NOTICE

Incorrect cleaning damages the appliance!

- ▶ Do not use cleaning agents in concentrated form.
- ▶ Do not use any scouring or abrasive sponges or steel wool.
- ▶ Do not use any sharp or abrasive cleaning agents, nor any that contain sand, chloride or acid.
- ▶ Do not use chemical solvents.
- ▶ Do not damage or remove the type plate on the inside of the appliance. It is important for the customer service.
- ▶ Do not pull off, bend or damage cables or other components.
- ▶ Do not allow any cleaning water to enter the drain channel, ventilation grille or electrical parts.
- ▶ Please use soft cleaning cloths and a universal pH-neutral cleaning agent.
- ▶ Please use cleaning and care products suitable for contact with foodstuffs in the appliance interior.

- ▶ Empty appliance.
- ▶ Pull out the power plug.



- ▶ Clean plastic outer and inner surfaces with lukewarm water and a little washing-up liquid.

Malfuctions

Do not apply stainless steel cleaning agent to glass or plastic surfaces to prevent them from being scratched. Darker areas at the beginning and quite an intensive colour of the stainless steel surface are normal.

NOTICE

The stainless steel doors are treated with a high quality surface coating and must not be treated with stainless steel care products.



Otherwise the surface coating will be affected.

- ▶ **Coated door surfaces** and **painted side walls** must only be wiped with a soft, clean cloth. If they are very dirty, use a little water or a neutral cleaner. A microfibre cloth may also be used.
- ▶ If the **stainless steel side walls** are dirty, clean them using a commercially available stainless steel cleaning agent. Then evenly apply the accompanying stainless steel care product, making strokes in the direction of the grain.

Do not clean the **glass door** with abrasive cleaning agents or rough cloths. Otherwise the surface and the frame may become dull or be scratched.

- ▶ Clean the glass door with a standard glass cleaning agent and a soft cloth.
- ▶ Wipe **wooden grid shelves** with a dry lint-free cloth.

Note

- ▶ Do not clean wooden grid shelves with water and washing-up liquid.
- ▶ Clean **other items of equipment** by hand with lukewarm water and a little washing-up liquid.

After cleaning:

- ▶ Wipe dry the appliance and items of equipment.
- ▶ Connect the appliance and switch it on again.
- ▶ Switch on SuperFrost (see 5.5.4) .
When the temperature is sufficiently cold:
- ▶ Put the food back inside.

6.4 Cleaning the IceMaker

The drawer of the IceMaker has to be emptied and slid in.

- ▶ To activate the setting mode: press the SuperFrost button *Fig. 3 (2)* for about 5 s.
 - ▷ The display indicates **c**.
 - ▷ The menu symbol *Fig. 3 (20)* shines.
 - ▶ Using the Up setting button, freezer compartment *Fig. 3 (5)* / Down setting button, freezer compartment *Fig. 3 (4)* select **1**.
 - ▶ To confirm: press the SuperFrost button *Fig. 3 (2)*.
 - ▶ Using the Up setting button, freezer compartment *Fig. 3 (5)* / Down setting button, freezer compartment *Fig. 3 (4)* select **1c**.
 - ▶ To confirm: press the SuperFrost button *Fig. 3 (2)*.
- ▷ The IceMaker moves into the cleaning position and switches off.
- ▶ To deactivate the setting mode: press the On/Off button, freezer compartment *Fig. 3 (3)*.



-or-

- ▶ Wait for 2 minutes.
- ▷ The temperature is indicated again in the temperature display.
- ▶ Remove the drawer.
- ▶ Clean the ice cube tray and drawer with warm water. If necessary, use mild washing-up liquid. Then rinse.
- ▶ Slide in the drawer again.
- ▶ Leave the IceMaker switched off in this position.

-or-

NOTICE

Rinse agent residue in the ice compartment and drawer.

Nausea or irritation of the mucous membrane.

- ▶ Remove rinse agent residue: Discard the first three batches of ice cubes.

- ▶ Switch the IceMaker on (see 5.5.10) .

6.5 Customer service

First check whether you can correct the fault yourself by reference to the list (see Malfunction). If this is not the case, please contact the customer service whose address is given in the enclosed customer service list.



WARNING

Risk of injury if repair work is not carried out professionally!

- ▶ Have any repairs and action - not expressly specified - on the appliance and mains cable carried out by service personnel only. (see Maintenance)

- ▶ Read the appliance designation

Fig. 25 (1), service No. *Fig. 25 (2)* and serial No. *Fig. 25 (3)* off the type plate located inside the appliance on the left-hand side.

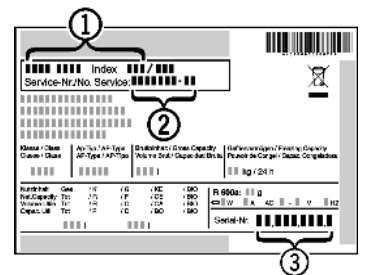

Fig. 25

- ▶ Notify the customer service, specifying the fault, appliance designation *Fig. 25 (1)*, service No. *Fig. 25 (2)* and serial No. *Fig. 25 (3)*.
 - ▷ This will help us to provide you with a faster and more accurate service.
- ▶ Keep the appliance closed until the customer service arrives.
- ▷ The food will stay cool longer.
- ▶ Pull out the mains plug (not by pulling the connecting cable) or switch off the fuse.

7 Malfunctions

Your appliance is designed and manufactured for a long life span and reliable operation. If a malfunction nonetheless occurs during operation, check whether it is due to a handling error. In this case you will have to be charged for the costs incurred, even during the warranty period. You may be able to rectify the following faults yourself:

Appliance does not work.

- The appliance is not switched on.
- ▶ Switch on the appliance.
- The power plug is not properly inserted in the wall socket.
- ▶ Check power plug.
- The fuse of the wall socket is not in order.
- ▶ Check fuse.

The compressor runs for a long time.

- The compressor switches to a low speed when little cold is needed. Although the running time is increased as a result, energy is saved.
- ▶ This is normal in energy-saving models.

A LED on the bottom rear of the appliance (at the compressor) flashes regularly every 15 seconds*.

- The inverter is equipped with a diagnostic LED.
- ▶ The flashing is normal.

Excessive noise.

- Due to the various speed steps, speed-regulated* compressors can generate different running noises.
- ▶ The sound is normal.

A bubbling and gurgling noise.

- This noise comes from the refrigerant flowing in the refrigeration circuit.
- ▶ The sound is normal.

A quiet clicking noise.

- The noise is produced whenever the refrigeration unit (motor) automatically switches on or off.
- ▶ The sound is normal.

A hum. It is briefly a little louder when the refrigeration unit (the motor) switches on.

- The refrigeration increases automatically when the SuperFrost, function is activated, fresh food has just been placed in the appliance or the door has been left open for a while.
- ▶ The sound is normal.
- The ambient temperature is too high.
- ▶ Solution: (see 1.2)

A low hum.

- The sound is produced by air flow noise of the fan.
- ▶ The sound is normal.

Vibratory noise.

- The appliance is not fixed to the ground. The running of the cooling unit therefore makes objects and adjacent furniture vibrate.
- ▶ Adjust appliance via the height-adjustable feet.
- ▶ Move bottles and containers apart.

Flow sound at the soft stop mechanism.

- The noise is produced when the door is opened and closed.
- ▶ The sound is normal.

Mould on wine bottles

- Similarly as with other forms of storage, a little mould may form depending on the type of adhesive used for the label.
- ▶ Remove residual adhesive.

The temperature display indicates: F0 to F9

- There is a fault.
- ▶ Please contact the after-sales service (see Maintenance).

The temperature display reads:FE

- There is a fault.
- ▶ Please contact the after-sales service (see Maintenance).

Power failure flashes in the temperature display . The highest temperature reached during power failure is indicated in the temperature display.

- The freezer temperature rose too high over the last hours or days due to a power failure or power interruption. When the power interruption is over, the appliance will continue to operate in the last temperature setting.
- ▶ To cancel the display of the warmest temperature: press alarm button *Fig. 3 (1)*.
- ▶ Check the quality of the food. Do not consume spoiled food. Do not re-freeze thawed food.

DEMO shines in the temperature display.

- The demo mode is activated.
- ▶ Please contact the after-sales service (see Maintenance).

The outer surfaces of the appliance are warm*.

- The heat of the refrigeration circuit is used to prevent condensate from forming.
- ▶ This is normal.

The IceMaker cannot be switched on.

- The appliance and therefore the IceMaker are not connected.

- ▶ Connect the appliance to the mains (see Putting into operation).

The IceMaker does not make any ice cubes.

- The IceMaker is not switched on.
- ▶ Switch on the IceMaker.
- The drawer of the IceMaker is not properly closed.
- ▶ Close the drawer properly.
- The water connection is not open.
- ▶ Open the water connection.
- The water intake to the IceMaker has been interrupted.
- ▶ Check the water connection (**see Putting into operation**).
- ▶ Check the hosing (**see Putting into operation**).
- The screen located in the end piece of the water intake hose or the screen located in the connecting piece on the appliance is blocked.
- ▶ Clean the screens.

The temperature is not cold enough.

- The door of the appliance is not properly closed.
- ▶ Close the door of the appliance.
- Insufficient ventilation.
- ▶ Keep ventilation grille clear, and clean it.
- The ambient temperature is too high.
- ▶ Solution: (see 1.2) .
- The appliance was opened too frequently or for too long.
- ▶ Wait to see whether the appliance reaches the required temperature by itself. If not, please contact the after sales service (see Maintenance).
- Too much fresh food was placed inside without SuperFrost.
- ▶ Solution: (see 5.5.4)
- The temperature is incorrectly set.
- ▶ Set the temperature to a colder setting and check after 24 hours.
- The appliance is too close to a source of heat (stove, heater etc).
- ▶ Change the position of the appliance or the source of heat.

The internal light does not come on.

- The appliance is not switched on.
- ▶ Switch on the appliance.
- The door was open longer than 15 min.
- ▶ The interior light automatically switches off if the door has been open for about 15 min.
- The LED illumination is defective or the cover is damaged:



WARNING

Risk of injury due to electric shock!

Live parts are located under the cover.

- ▶ Have the LED interior light changed or repaired only by the customer service or by specialized personnel trained for the purpose.



WARNING

Danger of injury by LED lamp!

The light intensity of the LED illumination corresponds to laser class 1/1M.

If the cover is defective:

- ▶ Do not look into the illumination with optical lenses from the immediate proximity. This can cause injury to the eyes.

Decommissioning

8 Decommissioning

8.1 Switching off the appliance

Note

- ▶ To switch off the entire appliance it is necessary only to switch off the freezer compartment.

8.1.1 Switching off the freezer compartment

- ▶ Press the freezer compartment On/Off button *Fig. 3 (3)* for approx. 2 seconds.
- ▷ The temperature displays are dark. The appliance is switched off.



8.1.2 Switching off the wine zone

- ▶ Press wine multi-temperature zone On/Off button *Fig. 3 (14)* for approx. 2 seconds.
- ▷ The temperature display of the upper wine zone *Fig. 3 (8)* / temperature display of the lower wine zone *Fig. 3 (7)* is dark. The wine zone is switched off.

8.2 Taking the appliance out of service

- ▶ Empty the appliance.
- ▶ Put the IceMaker in the cleaning position (see Maintenance).
- ▶ Switch off the appliance (see Decommissioning).
- ▶ Remove mains connector.
- ▶ Clean the appliance (see 6.3).



- ▶ Leave the door open to prevent odour.

9 Disposing of the appliance

The appliance contains some reusable materials and should be disposed of properly - not simply with unsorted household refuse. Appliances which are no longer needed must be disposed of in a professional and appropriate way, in accordance with the current local regulations and laws.



When disposing of the appliance, ensure that the refrigeration circuit is not damaged to prevent uncontrolled escape of the refrigerant it contains (data on type plate) and oil.

- ▶ Disable the appliance.
- ▶ Pull out the plug.
- ▶ Cut through the connecting cable.



Liebherr-Hausgeräte Ochsenhausen GmbH

Memminger Straße 77-79

88416 Ochsenhausen

Deutschland

home.liebherr.com